

# Performance Evaluation of Tractor Operated Ridger for Basin Lister to Prepare Watercourse for Irrigation

C. G. Pawar<sup>1</sup>, P. B. Kadam<sup>2</sup>, N. R. Gatkal<sup>3</sup>, S. M. Nalawade<sup>4</sup>

Department of Farm Machinery and Power Engineering, Dr. Annasaheb Shinde College of Agricultural Engineering and Technology, MPKV, Rahuri - 413 722, Ahmednagar, Maharashtra, India

(Received : 06.06.2024 Accepted : 10.07.2024)

---

## Abstract

One of the most efficient ways to conserve soil and water is through basin listing. Listing on the contour helps to store rainwater and minimize soil erosion. A tractor operated ridger for basin lister to prepare watercourse for irrigation was developed to achieve the proper furrow shape. Developed ridger consists of frame, furrow opener, shank, share, landside and three-point linkage attachment. The developed tractor operated ridger for basin lister to prepare watercourse for irrigation. was operated at three forward speeds, height of ridger and attachment of ridger to basin lister at 2, 3, 4 km h<sup>-1</sup>, 0.550, 0.525, 0.500 m and full sweep both sides, full sweep one side, half sweep both sides, respectively. The theoretical field capacity and field efficiency were 0.85 ha h<sup>-1</sup> and 80.28% respectively. The fuel consumption of tractor was 6.786 l ha<sup>-1</sup> and 3.078 l h<sup>-1</sup>. The operating cost of the machine was 1675 Rs. ha<sup>-1</sup> and 440.45 Rs. ha<sup>-1</sup>. The width of the furrow increases as the forward speed increases, the setting of ridger height increases and working cross-sectional area of ridger attachment increases. The optimized parameter for developed tractor operated ridger for basin lister to prepare water courses was 2 km h<sup>-1</sup> forward speed, 0.500 m height of ridger and full sweep both sides.

**Key words : Ridger, Basin lister and Furrow.**

---

One of the most efficient ways to conserve soil and water is through basin listing, which is done with the help of a tool called a basin lister. Basin listing gives rainwater the most time possible to permeate the soil. In alluvial soils, where water penetrates slowly and needs to stay in place for a long time to guarantee appropriate irrigation, this method should be used. The technique of creating alternate furrows on the ground that have a certain width is known as "basin listing". Listing on the contour helps to store rainwater and minimize soil erosion since the basins are shaped like little dams. Depending on the field's slope, either thin or broad-based bunds should be formed at proper intervals. The bunds improve soil moisture storage and increase infiltration by catching rainwater in the inter-bund gap. The inter-bund gap needs to be levelled in order to provide uniform water

distribution and get rid of water stagnation in spots. The basin lister technique is used for moisture conservation and also for irrigation of rabi crops.

The current agricultural situation focuses on increasing water productivity in the land used to feed the nation's expanding population so there is need to conserving soil moisture, this conservation of the water content of agricultural produces soils is the most essential for increasing the amount of moisture that crops receive. Water conservation is especially crucial for dry land and rainfed agriculture, the In-situ moisture conservation techniques must be used to increase the moisture availability to agricultural crops by lowering runoff rates, temporarily holding water on the soil's surface to extend the infiltration window and altering the land's contours to allow water to gather between fields are just a few of the numerous measures that are

encouraged. Previously, efforts to preserve moisture were concentrated on creating various forms of bunds to halt soil erosion and preserve the slope of the ground (Muthamilselvan *et al.* 2004).

The geography of the area where a basin is being built largely determines its shape and design, the basin construction tools can be as basic as manual hoes or shovels or as sophisticated as hydraulic motor-tripped mechanical devices. Raising shovels, tripping shovels, reservoir insertion equipment and check basin formers are examples of mechanized basin forming machinery that is readily available for purchase. The initial result of implementing basin tillage results in the formation of small earthen dams or dikes at regular intervals across the furrows of a ridge furrow tillage system. The terms used to describe the tillage of a basin include tie ridges, furrow damming, furrow dikes, basin listing and micro basin tillage (Jones and Clark, 1987).

The ridges and furrows are made across the slope, 0.30 to 0.45 m wide by 0.15 to 0.20 m high furrows are made over the hill, this furrows safely direct the runoff water towards the basins when it rains. When the intensity of rainfall is high, the basins always stay away from standing water, but when intensity is low the basins gather and store water during dry periods; all these broad row areas are useful for soil holding of water and then it works for a moisture conservation. Basins gather and store water during periods of lesser rainfall intensity, both deep red soil and medium to deep black soil are suitable for the moisture conservation. For soil holding of the basins, you may grow broad row crops like cotton, maize, chilly, tomatoes and other crops on the rows of basins, because of the high lateness of this site. Also, a short bund is used to moisture conservation by unite or tie the ridges at the intervals of 2 to 3 metres along the furrows in the modified ridges and furrows

method known as tie ridging, random tie ridging is another version that makes use of discontinuous ties.

## Material and Method

**Experimental site :** The development of tractor operated ridger for basin lister to prepare watercourse for irrigation was carried out in department of Department of Farm Machinery and Power Engineering, Dr. Annasaheb Shinde College of Agricultural Engineering and Technology, MPKV, Rahuri, Ahmednagar, Maharashtra, India. The performance evaluation was carried out in field of Mahatma Phule Krishi Vidyapeeth, Rahuri, Maharashtra, India.

The desirable criteria for design of basin lister with ridger should be as per following assumptions.

- i. Sturdy construction with low maintenance requirements.
- ii. Easily attachable and detachable to the developed basin lister.
- iii. Capable of high-speed operation.
- iv. Capable of constructing a ridges and furrows of sufficient size and capacity to prevent water loss from intense velocity.
- v. Economical to purchase, maintain and operate

### Components of existingbasin lister :

The existing basin lister was created that based on design calculations to automatically create a continuous basin of 6 x 2 m and be hauled by a tractor for in-place moisture conservation.

**Main frame :** The basin lister's main frame was constructed from C-channel that measured 75 x 40 x 5 mm. The overall dimensions of main frame including front width is 1750 mm, while the machine's length is 1200 mm. Various attachments were mounted to this basic frame with various fitments, including aside bund former unit, alister unit, a trigger mechanism

with power transmission, a cam follower mechanism and hitching system. The side bund forming unit is required to produce two side bunds and it is attached to the front of the main frame. The tie ridger or lister unit was fitted to the back end and carry the soil for tie bund there until the trigger mechanism was activated. After disengagement of cam the tie ridge former released the gathered soil once the trigger was released and formed the tie ridge at the appropriate spacing, which was 6 metres. The main frame, to which the ground wheels, chain and sprocket system delivered power, was mounted with the trigger mechanism with cam and follower.

**Side bund former :** Side bund former is one of the primary and important components for forming the basin listers side bund. It consists of 2 wing blades which are attached together at the center of the machine, the length of the 2 wing plates is 1225 mm and heights at front and rear end are 175 mm and 220 mm. The soil scraping blade of side bund former have thickness of 6 mm.

**Cross / lister bund former :** As a cross bund former, the lister unit joins the two side bunds along the selected length of the basin. The lister blade was 1650 x 225 x 7 mm in size and it was firmly welded to a 60 mm diameter bush that was fixed at three points on the solid 30 mm shaft. The inner shaft is 30 mm in diameter and 1800 mm long, and it is installed in a pedestal bearing on both sides to provide rotary movement. The outer lister bush is welded to the inner shaft, which is 588 mm from the center bush in equidistance.

**Stop and release mechanism for lister blade :** The stopper mechanism was designed to lock the lister blade in the proper position and it will continue to scrape the soil until the stopper is released. When the stopper is activated, the lister blade scrapes soil off the bed and collects it until it is released. Due to the cam

and follower, the trigger was pushed back after the machine had travelled 6 meters, releasing the lister blade. Due to soil thrust and forward movement of the tractor, the lister blade rotated, releasing the gathered soil mass and forming a lister bund or cross bund. Due to spring tension, the stopper will return to its original position after passing the cam from the follower, stopping then extending blade from scraping and collecting soil mass from the bed for the next lister bund. The ground wheel mechanism operated there lease mechanism when it had travelled the appropriate distance, which was equivalent to the basin length of 6m. The following sub-components made up the entire mechanism.

**Trigger mechanism :** The trigger mechanism was made of a solid 20 mm shaft that is housed in a hollow MS pipe housing hub with a 40 and 25 mm outside and inside diameter, respectively. At the back end of the trigger shaft, a washer collar measuring 60 mm in diameter is fitted with a nut and bolt locking system. The spring was placed in the outer hollow pipe housing in such a way that it kept the trigger shaft pointing towards the lister assembly, there by stopping the blade. The rear collar washer is pushed backward by the cam and follower lever. The spring strain pulls the trigger shaft back and releases it.

**Cam and follower :** The trigger lever, which was activated by the cam and follower, dragged the trigger stopper to the lister blade. The ground wheel gave power to the cam on both sides of the cam and follower. The cam will move the follower, which will activate the follower lever, which will draw the trigger mechanism backward, allowing the lister blade to be released. The cam was built from a 16 mm MS plate. The cam was 140 mm in length. Two levers were installed at an angle of 110° on the follower. The first lever was built of a 50 x 5 mm MS flat with a length of 115 mm, while these

condlever was made of two adjacent 35 x 5 mm MS plates placed at 40 mm apart with a length of 250 mm. The fulcrum for counter displacement is the connecting vertex of these two levers.

#### Power transmission mechanisms :

Power was necessary to pull the stopper lever after every 6 m distance travelled in order to actuate the stopper. The vertical lever of the follower drew the stopper back. The cam pulls the horizontal lever of the follower upward, which moves the vertical lever of the follower in the forward direction, because the vertical lever of the follower was fitted at an angle with the horizontal lever of the follower. This forward motion of the vertical lever of the follower will push the stopper back into position, releasing the horizontal list erblade, and due to the forward motion of the machine and the soil thrust of the collected soil by the lower lister blade, it will movesuddenly, releasing the soil trapped in between the two lister blades to form a cross bund or listerbund. Chain and sprocket arrangement having a 50:13 speed reduction ratio was used to deliverpower to the cam and follower. A chain was used to connect the sprockets. The 13 teeth sprocket was attached to a shaft between the two ground wheels, while the 50 teeth sprocket was attachedto the cam shaft. The tractor's gear ratio of 3.85 causes a trigger action after every 6 m distance travelled, resulting in the creation of a list erbund.

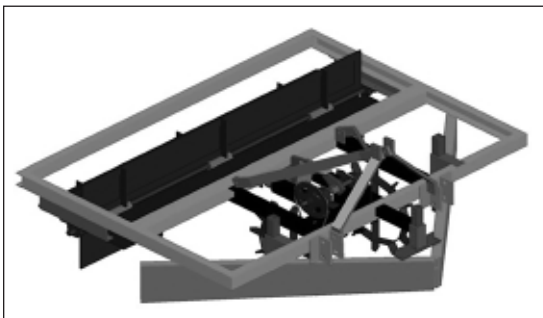

**Fig. 1.** Isometric view of existing basin lister in cad design

**Estimation of required pull :** The implement was made for tractors with 45 horsepower and drawbar horsepower is equal to 60% of brake horsepower (Sharma, 2010). So, 27 hp was considered as the amount of available horsepower. The pull of the tool was estimated using equation.

$$\text{Pull} = \frac{(D_{\text{BHP}} \times 4500)}{\text{Speed (m/min)}}$$

Where,  $D_{\text{BHP}}$  stands for drawbar horse power (hp)

$$\text{Total width of ploughing} = 30 \times 2 = 60 \text{ cm}$$

$$\text{Pull} = \frac{27 \times 4500}{90}$$

$$\text{Pull} = 1350 \text{ kg i.e., } 13243.5 \text{ N}$$

(Since,  $D_{\text{bhp}} = 75\%$  of IHP, so we take a tractor of 36 Hp power)

Total draft is determined by the cross-sectional area of the furrow, soil resistance, and is given by (Sahay, 2011).

Total draf = Soil resistance x Furrow cross sectional area.

The entire width of operation in working and the operating depth of ridging are used to compute the furrow cross section area.

Furrow cross section = Total width x Working depth.

$$= 60 \times 25$$

$$= 1500 \text{ cm}^2 = 150000 \text{ mm}^2$$

$$\text{Total draft of implement} = 0.65 \times 1500$$

$$= 975 \text{ kg i.e., } 9564 \text{ N}$$

Required pull is the real force needed to move the object being pulled by (Sharma, 2010),

$$\begin{aligned}
 \text{Required Pull} &= \text{Total Draft} / \cos (\Theta) \\
 &= 9564 / \cos (20) \\
 &= 10178 \text{ N}
 \end{aligned}$$

The required pull is calculated as 10178 N, and available tractor pull is 13243 N.

Development of components of ridger to tractor drawn basin lister

Detailed design considerations of these components are discussed below along with their orthographic and isometric drawings (Fig. 3.1 to Fig.3.3).

**Development of shank :** The ridger shank is supported by the standard, which is attached to the basin lister's main frame. These values were used to determine the stress bearing capacity of shank. (Marode, 2013). The axial stress is calculated as 5.70 MPA.

**Development of standard for main frame attachment :** The standard for a ridger plough is a hollow channel square beam made from mild steel by welding two C-type channels to each other (Sharma, 2010). The standard beam is generally designed for extreme conditions hence unit draft of heavy soil was considered and taken as  $1.25 \text{ kg cm}^{-2}$ , width of beam was 10 cm. and ground clearance were taken as 45 cm. Hence total draft for extreme condition was calculated as 975 kg. Hence the standard is designed for the thickness of material to be used and the allowable stress is checked against the maximum applied stress. (Sharma,2010).The stress induced in frame is calculated as  $3.67 \text{ N mm}^{-2}$ .

**Development of landside :** Landside is long flat metal piece welded to the frog and one end to the share of ridger. The force acting on the landside is about 25% to 50% of longitudinal force acting on ridger bottom. Width of landside is taken as one third of throat width of share of

ridger bottom. The length and thickness of the landside is calculated by (Yoganandiet al, 2016). The required draft is calculated as 450 kg and side draft is 180 kg.

**Development of Share :** The share of ridger is actual soil working component. Share is designed for maximum stress developed due to soil on share. The detailed share geometry is discussed by (Sharma, 2010).

$$\text{Soil pressure on share} = \frac{\text{Total design draft}}{\text{Total area of share}}$$

**Share thickness :** Calculated stress was delivered during the bending of a rectangular plate. The thickness of the share was estimated based on this stress.The share thickness is calculated as 5 mm.

**Development of mould board :** The mould board is designed for the general purpose as per the standard literature available. (Jeshvaghani *et al.*, 2013). According to Jeshvaghani *et al.*, 2013 the overall length of mould board was taken as 410 mm and width as 260 mm with thickness of 6 mm. The radius of curvature of mould board plough was 25 mm and four holes are provided in the mould board to fix the mould board with frog.

**Development of frog :** The frog is rigid component which connects share, mould board and landside with considerable strength. The

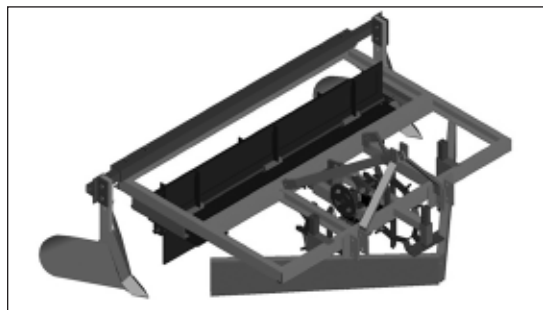

**Fig. 2.** Three-dimensional isometric representation of a basin lister with two ridging tool attachment in a cad design.

frog is designed in such way that it supports share and landside while connected to ridger. The one part of frog was designed as flat plate. The length and width of flat plate was 380 mm and 50 mm respectively. The flat plate connects to the landside of the ridger. The other part of frog is curved plate which connects to the mould board of the ridger. There are holes of 13 mm diameter are provided on the frog for attachment to the landside and mould board.

### Measurements of the basin geometry

**a) Furrow width and height :** With the use of a soil profile meter, the width and height of the furrow and ridge width were measured and documented.

**b) Ridge width and height :** With the use of a soil profile meter, the width and height of the ridges were measured and documented.

**c) The spacing between the cross and side bunds :** Using a 30 m measurement tape, the distance between two side bunds and cross bunds were measured.

**Draft Measurement :** The draft of implement was calculated by,

$$\text{Draft} = \text{On load draft} - \text{No load draft}$$

**Theoretical field capacity :** The following formula was used to calculate the theoretical field capacity:

$$\text{Theoretical field capacity (ha h}^{-1}\text{)} = \frac{\text{Width (m)} \times \text{Speed (km h}^{-1}\text{)}}{10}$$

**Effective field capacity :** The effective field capacity is given by,

$$\text{EFC (ha h}^{-1}\text{)} = \frac{\text{Area covered (ha)}}{\text{Time (h)}}$$

**Field efficiency :** The field efficiency is given by,

$$\text{Field efficiency (\%)} = \frac{\text{EFC}}{\text{TFC}} \times 100$$

### Fuel consumption

$$\text{Fuel consumption (l h}^{-1}\text{)} = \frac{\text{Fuel consumed during field operation (l)}}{\text{Time required for operation (h)}}$$

**Wheel slippage :** The wheel slip was calculated by the formula

$$\text{Wheel slip (\%)} = \frac{(A - B)}{A} \times 100$$

Where, A = Number of revolutions under load, B = Number of revolutions under no load, Power requirement for implement

The following formula can be used to determine the amount of power needed to operate the implement:

$$\text{Power requirement (hp)} = \text{Draft (kg)} \times \text{speed (km h}^{-1}\text{)} / 270$$

### Result and Discussion

The soil moisture content, bulk density and soil cone index before primary tillage operation for the tractor drawn implements at field performance test was 12 to 14%, 1.426 to 1.510 g cc<sup>-1</sup> and 800 - 1000 kPa, respectively.

The developed tractor operated ridger for basin lister to prepare watercourse for irrigation. was operated at three forward speeds, height of ridger and attachment of ridger to basin lister at 2, 3, 4 km h<sup>-1</sup>, .550, 0.525, 0.500 m and Full

**Table 1.** Performance parameters of developed tractor operated ridger for basin lister to prepare watercourse for irrigation

Particular	Value
Width of furrow with respect to speed, m	0.668
Width of furrow with respect to height, m	0.653
Width of furrow with respect attachment, m	0.659
The theoretical field capacity, ha h <sup>-1</sup>	0.85
Field efficiency %	80.28
The fuel consumption, l h <sup>-1</sup>	3.078
Cost of operation, Rs. ha <sup>-1</sup>	1675
Wheel slippage, %	5.41

sweep both sides, Full sweep one side, Half sweep both sides, respectively.

The speed level of  $2 \text{ km h}^{-1}$  gives the width of 0.668 m which is closer to the assumed value. The width of the furrow increases as the forward speed increases; this may be due to the increase in tripping action by the ridger blade to outward soil throw to form the ridge. The level of 0.50 m height from ground level gives the width of 0.653 m which is closer to the assumed value. The width of the furrow increases as the setting of ridger height increases; this may be due to the increase in soil penetration and throw by the ridger blade during working action to form the ridge. The attachment of full sweep one side gives the width of 0.659 m which is closer to the assumed value. From the study it is conclude that, the width of the furrow increases as the working cross-sectional area of ridger attachment increases. The basin lister functions smoothly and performs well in soil clod size less than 4.39 mm. The observed draft of 299.4 kgf at half sweep both side ridger at 0.525 m ridger height and a forward speed of  $2 \text{ km h}^{-1}$  is closer to the intended draft of 275 to 300 kgf. The draft increases with increase in speed of tractor, with increase in depth of operation of ridging unit and with increase in working cross sectional area. The theoretical field capacity and field efficiency were  $0.85 \text{ ha h}^{-1}$  and 80.28% respectively. The fuel consumption of tractor was  $6.786 \text{ l ha}^{-1}$  and  $3.078 \text{ l h}^{-1}$ . The operating



**Fig. 3.** Developed tractor operated ridger for basin lister.

cost of the machine was  $1675 \text{ Rs. ha}^{-1}$  and  $440.45 \text{ Rs. ha}^{-1}$ .

## Conclusion

One of the most efficient ways to conserve soil and water is through basin listing. Listing on the contour helps to store rainwater and minimize soil erosion. To achieve the proper shape of furrow a development of tractor operated ridger for basin lister to prepare watercourse for irrigation was developed. The developed basin lister gives width of 0.668, 0.653 0.659 m at the speed of  $2 \text{ km h}^{-1}$ , height of 0.50 m and attachment of full sweep one side. The width of the furrow increases as the forward speed increases; this may be due to the increase in tripping action by the ridger blade to outward soil throw to form the ridge. The width of the furrow increases as the setting of ridger height increases; this may be due to the increase in soil penetration and throw by the ridger blade during working action to form the ridge. From the study it is conclude that, the width of the furrow increases as the working cross-sectional area of ridger attachment increases. The observed draft was 299.4 kgf at half sweep both side ridger at 0.525 m ridger height and a forward speed of  $2 \text{ km h}^{-1}$ . The effective field capacity, theoretical field capacity, fuel efficiency and fuel consumption were  $0.672 \text{ ha h}^{-1}$ ,  $0.85 \text{ ha h}^{-1}$ , 80.28%, and  $6.786 \text{ l ha}^{-1}$ , respectively. The operating cost of the machine was  $1675 \text{ Rs. ha}^{-1}$ .

## References

- Anonymous, 2021a. Indian economy and agriculture. Retrieved on 15 may 2021. <http://www.fao.org/india/fao-in-india/india-at-a-glance/en/>.
- Anonymous, 2021b. Status of farm mechanization in India. Retrieved on 24 may 2021. <https://www.nabard.org/writereaddata/file/NSP%20Farm%20Mechanisation>.
- Jones, O. R., Clark, R. N. 1987. Effects of furrow dikes on water conservation and dry land crop yields. Soil Science society of America journal. 54: 1307-1314.

- Kadam, P. B., Mathur, S. M., Nalawade, S. M., and Upadhye, S. K., 2020. Effect of basin listing technology for *insitu* moisture conservation in Vertisols. International journal of agriculture sciences, 12: 9975-9977.
- Manian, R., M. Muthamilselvan and K. Kathirvel, 2008. Performance evaluation of basin lister cum seeder. Madras Agric. J., 95:1-6.
- Marode, R. V., Tayade, G. P., Agrawal, S. K. Design and implementation of multi seed sowing machine. Int. J. Mech. Eng. and Rob. Res. 2(4).
- Muthamilselvan, M., R. Manian and K. Kathirvel, 2004. Design Principles of Basin Lister Cum Seeder. Karnataka J. Agric. Sci. 18(2): 447-455.
- Sahay, J. 2009. Elements Of Agricultural Engineering. Standard Publisher Distributor.
- Sharma, D. N. and Mukesh, S. 2010. Farm Machinery Design Principles and Problems. Jain Brothers Publisher.
-